

AURATON 1100E

OPERATING INSTRUCTIONS FOR AURATON 1100E CONTROLLERS

1. Application

The AURATON 1100E is a modern processor-based controller, designed for work with a central heating or a hot water circulating pump.

In a central heating system, the controller switches the circulating pump on or off automatically depending on the water temperature.

In a hot water system, the controller maintains a constant water temperature in the tank or in the hot water installation.

The digital sensor of the controller measures water temperature in the feed line of the central heating system or in the hot water tank.

The controller-pump assembly forces water to circulate in central heating installations with a coal or gas boiler.

In a central heating installation with a coal boiler, the controller will switch off the circulating pump, when the boiler stops burning. Pumping water while the boiler is not burning is inadvisable, because the chimney draft makes that water in the boiler is getting cold faster than water in the radiators. The optimum temperature can be set on the controller (usually about 40°C).

In a central heating installation with a gas boiler, the temperature setting on the controller must be lower than the temperature setting on the thermostat in the central heating boiler. Setting the controller temperature above the dew point will prevent the boiler from sweating while heating up water in the central heating system.

The AURATON 1100 E central heating pump controller is equipped with the ANTI-STOP system, which prevents the pump rotor from seizing when not used.

After the heating season, the pump is started automatically every 14 days to run for 30 seconds. The controller should be left turned on for the system to work after the season end.

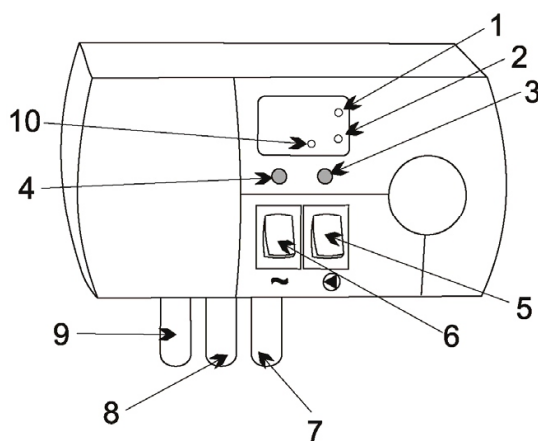

1. Hot water mode operation indicator
2. Central heating mode operation indicator
3. Temperature setting +
4. Central heating mode / hot water mode switch, temperature setting -
5. Continuous pump operation switch
6. Power switch
7. Temperature sensor
8. Pump power supply cable, 230 V AC
9. Power supply cable, 230 V AC
10. Pump operation indicator

2. Installation

- a. Mounting the controller
 - mount the controller on a wall or a console, using two screws (expansion plugs with screws are supplied with the controller),
 - fix the outgoing cables to the wall, using holders.
- b. Mounting the sensor
 - **do not immerse the sensor in liquids and do not install it in flue gas outlets,**
 - install the sensor on an uncovered outlet pipe of the central heating boiler (as close as possible to the boiler) or on the hot water tank,
 - press the sensor against the pipe, using a band clip,
 - it is advisable to wrap the outlet pipe section between the boiler and the sensor in insulating material,
 - the maximum temperature measurement value is 99°C.

NOTE: If a coal boiler and a gas boiler are used together in the same central heating installation, the sensor should be mounted at the connection point of both outlets and insulated.

- c. Connecting the power supply cable to the pump
 - connect the yellow or yellow/green wire (ground wire) to the (\perp) terminal,
 - connect the blue wire to the (N) terminal,
 - connect the brown wire to the (L) terminal.
- d. Checking the correct connection
 - check the correct connection of the cable and screw on the pump motor terminal box cover.
- e. Connecting the controller
 - after protecting the cables against accidental breaking, connect the power supply **cable to a grounded 230V/50Hz mains socket.**

NOTE: The ambient temperature in the place of installation of the controller should not exceed 40°C.

3. Operating the controller

- a. Turning on the controller
 - set the switch marked with (\sim) (the one on the left) in the "I" position,
 - upon turning on, all display segments will light for about 2 seconds,
 - the controller will then show the current sensor temperature, switching on the relay according to the factory setting (the threshold temperature is set to 50°C).
- b. Display description (information display)
 - in normal operation mode, the controller displays the current sensor temperature,
 - flashing display shows the central heating or hot water pump temperature setting,
 - lighted red LED – the controller is switched to the hot water pump operation mode,
 - lighted green LED – the controller is switched to the central heating pump operation mode,
 - lighted point after the second digit – indicates that the central heating or hot water pump is in operation.

c. Changing the temperature values

- select the hot water or central heating pump operation mode with the left-hand button under the display,
- press the right-hand button under the display – the digits will start flashing and will indicate the current set value,
- the desired temperature can be set using the right-hand (increasing) or the left-hand (decreasing) button under the display, after setting the temperature, wait for about 4 seconds, until the display stops flashing and the temperature is stored in the memory,
- the display will show the current sensor temperature.

d. Automatic operation

- set the right-hand switch marked with (▶) in the "0" position,
- the controller will switch the pump on and off depending on the temperature setting,
- in the central heating system, the pump is switched on, when the temperature at the sensor location is higher than the set value by 2°C, and switched off, when the temperature falls by 3°C below the set value (a hysteresis of 5°C).
- in the hot water system, the pump is switched on, when the water temperature at the sensor location falls by 2°C below the set value, and switched off, when the temperature exceeds the set value by 1°C.

e. Continuous operation

- set the switches marked with (∞) and (▶) in the "I" position,
- the pump will run continuously regardless of the hot water or central heating operation mode of the controller,
- the pump will run continuously regardless of the temperature setting of the controller and the real temperature at the sensor location.

NOTE: If the switch is set in the "I" position in the hot water operation mode, the hot water pump will be switched off when the temperature reaches 90°C and will remain switched off until the temperature falls below 90°C.

4. Technical data

- a. temperature setting range: 10°C – 80°C
- b. measurement range: 1°C – 99°C
- c. central heating hysteresis (on/off value difference): 5°C
- d. hot water hysteresis (on/off value difference): 3°C
- e. supply voltage: 230V AC
- f. maximum load: 6A AC

5. Kit contents

- a. controller with sensor
- b. sensor band clip
- c. expansion plugs
- d. instruction
- e. mounting template

6. Controller connection diagrams

Example connection diagrams. The presented diagrams are simplified and do not contain all the elements required for the correct operation of the installation.

With hot water tank

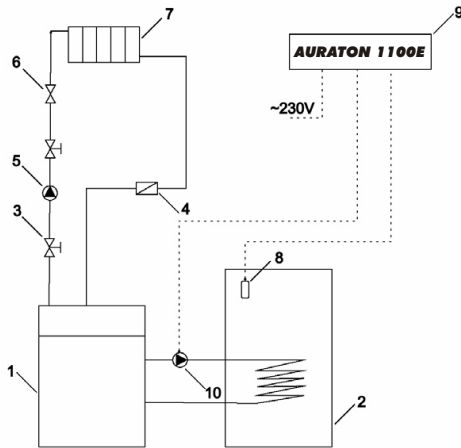

Legend:

1. Boiler
2. Hot water tank
3. Cut-off valve
4. Mesh filter
5. Central heating pump
6. Check valve
7. Heat receiver – radiator
8. Temperature sensor
9. Hot water controller
10. Hot water pump

For central heating boiler pump

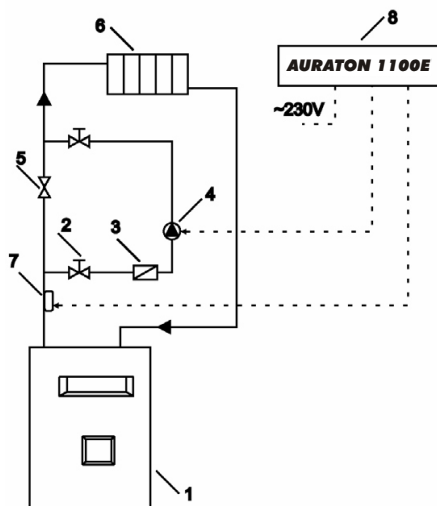

Legend:

1. Central heating boiler
2. Cut-off valve
3. Mesh filter
4. Central heating pump
5. Check valve
6. Heat receiver – radiator
7. Temperature sensor
8. Central heating controller

In hot water circuit

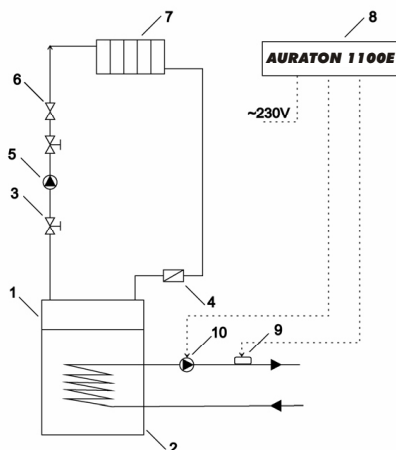

Legend:

1. Central heating boiler
2. Hot water tank
3. Cut-off valve
4. Mesh filter
5. Central heating pump
6. Check valve
7. Heat receiver – radiator
8. Hot water circulation controller
9. Temperature sensor
10. Hot water circulating pump